

The new dimension to mobile ice maintenance



Product sheet
Pinguino







The handy ice resurfacers for events and mobile rinks, ideal for ice surfaces up to 800 m² / 8,600 ft².

Whether it's a sports event or an ice skating rink, you can easily keep your designated ice surface flawlessly maintained with Pinguino.

This innovative, compact ice resurfacers (measuring 3 meters in length and 2 meters in height / 10 ft length x 6.5 ft height) performs on par with larger professional machines: it efficiently planes the ice, ensuring perfect quality. Plus, its unique front seating position for the driver offers excellent visibility and a comfortably enjoyable driving experience.

Modern design, high quality, and easy maintenance – ice resurfacing for mobile rinks has never been this professional and comfortable!

	Snow tank volume	1 m ³ / compacted 1.25 m ³ 35.3 ft ³ / compacted 44.2 ft ³
	Water tank volume	340 l 90 gal
	Blade width	1,400 mm 55 1/8 in
	Fields of operations	Event / Small ice rinks

“Agile, comfortable to use and outstanding ice resurfacing: With the Pinguino, we create the perfect ice conditions for our events!”

Raphael Fink
Pond Hockey Championship
(Italy)





Safety and protective features

At WM technics, safety and health protection always come first. A thorough and independent inspection carried out by [Suva](#), the accredited and recognized Swiss certification body, confirms compliance with the European Directive 2006/42/EC, which regulates the level of protection against machinery-related accidents to ensure user safety.

suva
CERTIFICATION

In compliance with Suva certification No. E 7164/2.e

TECHNOLOGY

Explore the Pinguino's standard features and numerous optional extras. We are also happy to customize the Pinguino to meet your needs.



Technical specifications

Motor	Asynchronous motor
Drive power	10 kW
Battery Lithium	BlueLi 80V – 230Ah
Charger Power	3 kW
Battery charger connection	100-240 VAC / 50-60 Hz
Autonomy	approx. 2h 40 min.
Charging time for 80%	approx. 4h 20 min.
Weight when empty	1,230 kg (basic outfit) 2,690 lbs
Water tank	340 l 90 gal
Snow tank	1 m ³ / compacted 1.25 m ³ 35.3 ft ³ / compacted 44.2 ft ³
Transmission	Continuously adjustable hydraulic four-wheel drive
Axles	Single wheel drive
Steering	Hydraulic
Footbrake	Hydraulic
Parking brake	Mechanical parking brake on rear wheels
Hydraulic system	18 cm ³ axial piston pump for drive, 6 cm ³ work units + cylinder movements, 4.4 cm ³ steering
Diameter of screw conveyors	vertically ø 175 mm 6.9 in horizontally ø 170 mm 6.7 in
Tyres	5.00R12 83/81P 2 rows of spikes
Wheel rims	12" x 5" with hubcaps

Standard equipment

All-wheel drive
Parking brakes
2 board guide rollers
Water tank-snowbin made of stainless steel
Spring suspended drivers seat
Horn
Easily accessible engine compartment (tiltable driver's seat, hydraulically tiltable snowtank)
Hydraulic power steering
2 hydraulically powered screw conveyors
Hydraulic carriage pressure system
Hydraulic opening and closing of snow bin cover
Manual blade adjustment
Tiltable planing device / conditioner for easy, safe blade changing
Tiltable operator's platform (2 positions)
1 blade
1 towel
Scope of delivery set



In conformity with Suva no. E 7164/2.e type-examination certificates

Petrol / Gasoline

Technical specifications

Engine	Honda GX690RH, 2 cylinder 688 cm ³
Power	16.5 kW / 22.1 HP - 3,600 rpm
Weight when empty	1,100 kg (basic outfit) 2,425 lbs
Water tank	340 l 90 gal
Snow tank	1 m ³ / compacted 1.25 m ³ 35.3 ft ³ / compacted 44.2 ft ³
Fuel tank	15 l 4 gal
Transmission	Continuously adjustable hydraulic four-wheel drive
Axles	Single wheel drive
Steering	Hydraulic
Footbrake	Hydraulic
Parking brake	Mechanical parking brake on rear wheels
Hydraulic system	18 cm ³ axial piston pump for drive, 6 cm ³ work units + cylinder movements, 4.4 cm ³ steering
Diameter of screw conveyors	vertically ø 175 mm 6.9 in horizontally ø 170 mm 6.7 in
Tyres	5.00R12 83/81P 2 rows of spikes
Wheel rims	12" x 5" with hubcaps

Standard equipment

All-wheel drive
Parking brakes
2 board guide rollers
Water tank-snowbin made of stainless steel
Spring suspended drivers seat
Horn
Easily accessible engine compartment (tiltable driver's seat, hydraulically tiltable snow tank)
Hydraulic power steering
2 hydraulically powered screw conveyors
Hydraulic carriage pressure system
Hydraulic opening and closing of snow bin cover
Manual blade adjustment
Tiltable planing device / conditioner for easy, safe blade changing
Tiltable operator's platform (2 positions)
1 blade
1 towel
Scope of delivery set



In conformity with Suva no. E 7164/2.e type-examination certificates



Scope of delivery



1 blade in
transport sheath



Towel felt



2 rubber mats



6 mm hex socket
T wrench

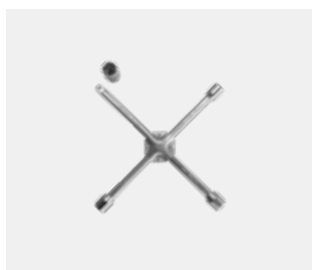

Cross-key with nut



Laceration-proof
safety gloves



Grindstone

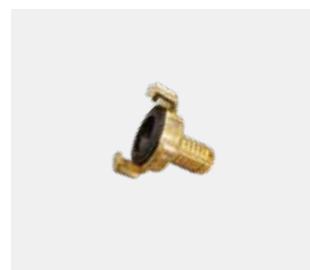

Water connector

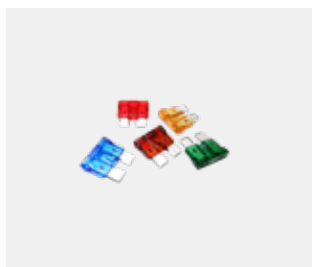

Fuse set

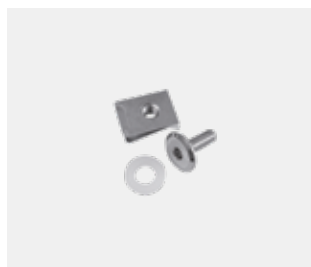

Set ABS
fastening material



Safety and
Lifting bar



Charging Cable
Lithium



Instruction
manual



Online spare
parts catalogue

Dimensions

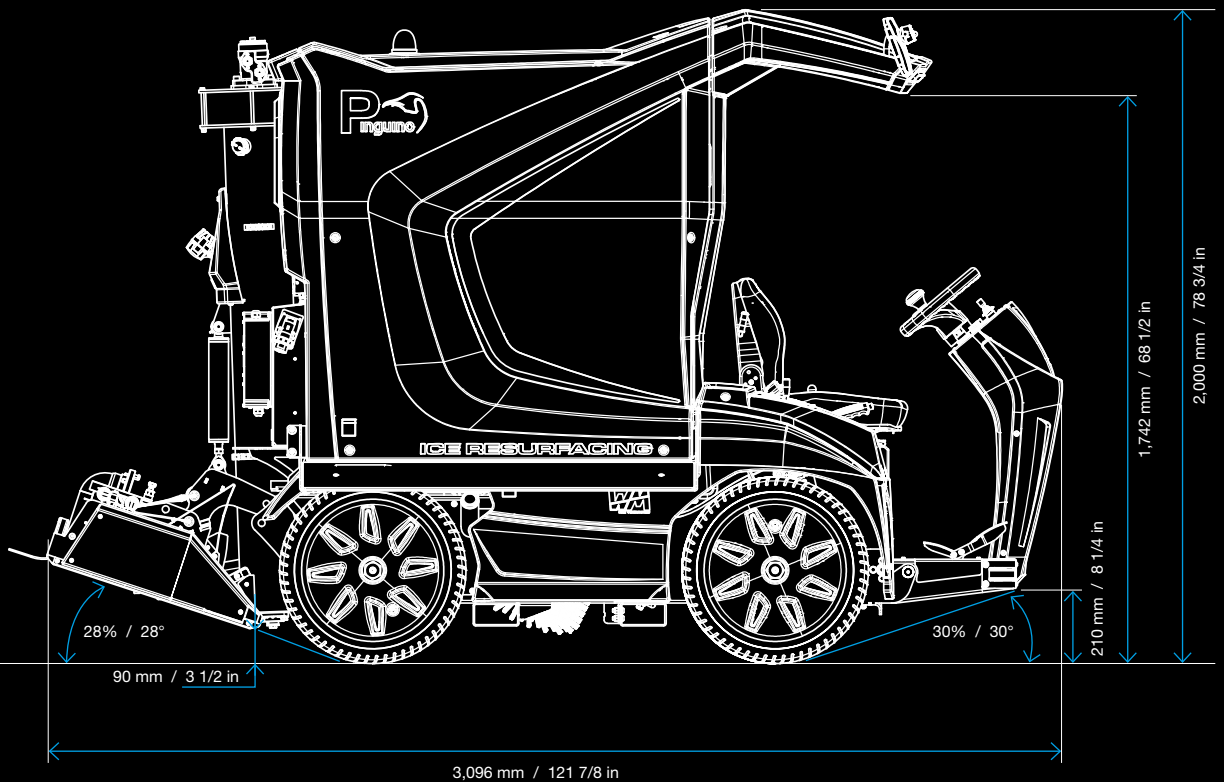
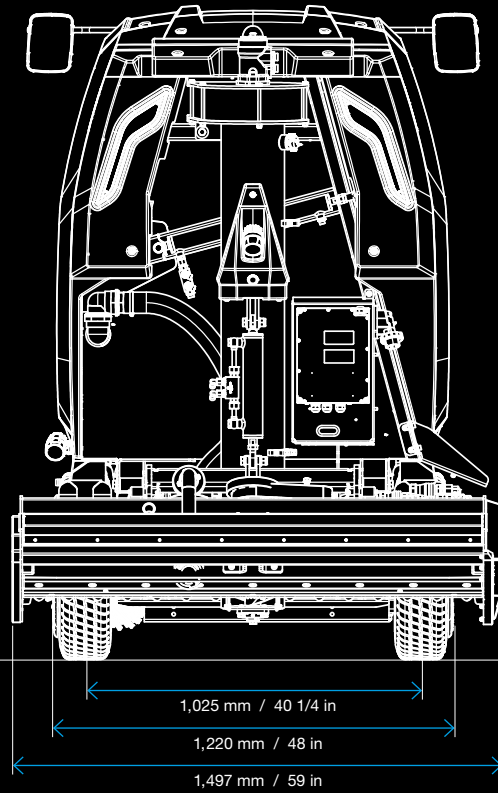
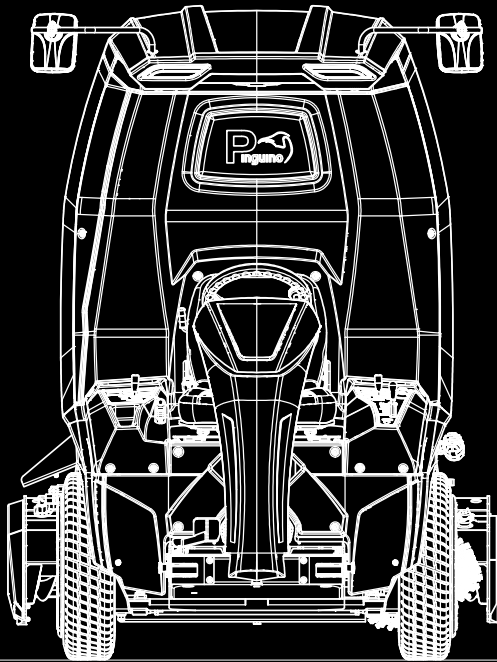

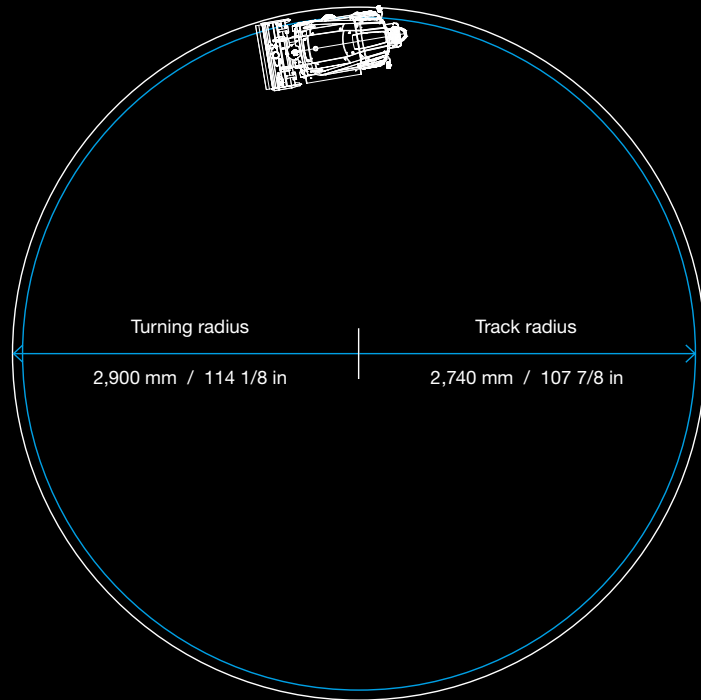
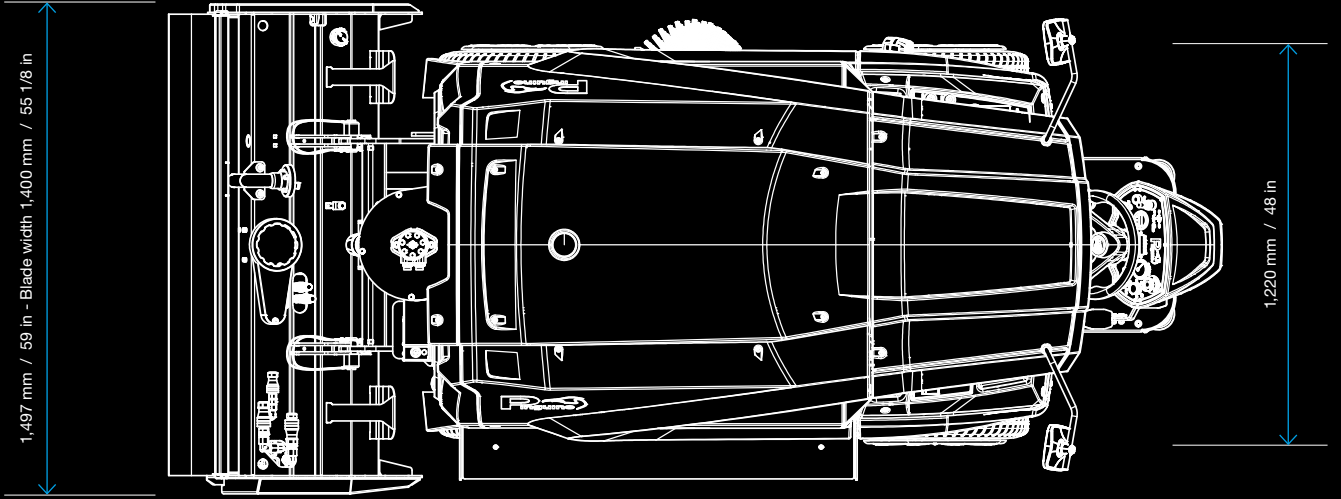

WM technics GmbH

Breiner Straße 15
I-39053 Blumau
T. +39 0471 353 332
info@wm-technics.com
wm-technics.com

